

UNITED STATES PATENT AND TRADEMARK OFFICE

BEFORE THE PATENT TRIAL AND APPEAL BOARD

ELBIT SYSTEMS OF AMERICA, LLC,
Petitioner,

v.

THALES VISIONIX, INC.,
Patent Owner.

Case IPR2015-01095
Patent 6,474,159 B1

Before TRENTON A. WARD, GREGG I. ANDERSON, and
WILLIAM M. FINK, *Administrative Patent Judges*.

FINK, *Administrative Patent Judge*.

FINAL WRITTEN DECISION
35 U.S.C. § 318(a) and 37 C.F.R. § 42.73

I. INTRODUCTION

On April 23, 2015, Elbit Systems of America, LLC (“Petitioner”) filed a Petition requesting an *inter partes* review of claims 1–7, 10–13, 20, 22–28, 31–34, and 41 of U.S. Patent No. 6,474,159 B1 (Ex. 1001, “the ’159 patent”). Paper 1 (“Pet.”). Thales Visionix, Inc. (“Patent Owner”) did not file a Preliminary Response. On October 26, 2015, we granted the Petition and instituted trial as to claims 1–7, 10–13, 20, 22–28, 31–34, and 41 of the ’159 patent on the grounds of unpatentability, under 35 U.S.C. § 103, that were alleged in the Petition. Paper 10 (“Inst. Dec.”).

After institution, Patent Owner filed a Patent Owner Response (“PO Resp.”). Paper 20. Petitioner filed a Reply to the Patent Owner Response. Paper 25 (“Pet. Reply”). An oral hearing for IPR2015-01095 was held on July 20, 2016. The transcript of the hearing has been entered into the record. Paper 45 (“Tr.”).

This Final Written Decision is issued pursuant to 35 U.S.C. § 318(a). For the reasons explained below, we conclude Petitioner has demonstrated, by a preponderance of the evidence, that claims 1, 2, 6, 7, 10, 11, 12, 20, 22, 23, 32, 33, and 41 of the ’159 patent are unpatentable. However, we conclude Petitioner has not demonstrated, by a preponderance of the evidence, that claims 3, 4, 5, 13, 24, 25, 26, 27, 28, 31, and 34 of the ’159 are unpatentable.

A. Related Proceeding

According to the parties, the ’159 patent is involved in at least the following lawsuit: *Thales Visionix, Inc. v. United States*, No. 1:14-cv-00513-TCW in the United States Court of Federal Claims. Pet. 4; Paper 5, 2. Petitioner is a third-party defendant in the lawsuit. Pet. 4.

B. The '159 Patent

The '159 patent relates to motion tracking in a head-mounted display (“HMD”) application using an “inertial head tracking system.” Ex. 1001, Abstract. Figure 4 of the '159 patent is reproduced below:

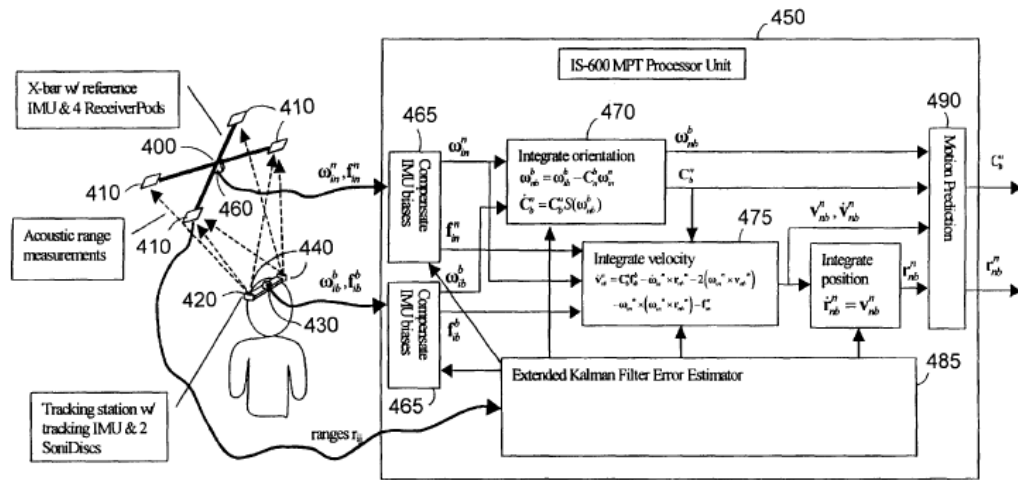

FIG. 4

Figure 4 illustrates a head tracking system with tracking inertial measurement unit 420 in accordance with the claimed invention. *Id.* at 8:58–66. According to the '159 patent, helmet-mounted inertial trackers were not previously used in tracking motion relative to a moving platform, such as on a ship, instead of relative to earth. *Id.* at 1:22–31. To overcome this limitation, the claimed invention “rigidly attach[es]” a second inertial sensor to the moving platform, in addition to the first inertial sensor mounted on the helmet. *Id.* at 1:45–49. An element is coupled to the first and second sensors and is configured to determine an orientation of the object relative to the moving platform. *Id.* at 1:58–62.

C. Illustrative Claims

Of the challenged claims of the '159 patent, claims 1 and 22 are independent claims. Claims 2–7, 10–13, and 20 depend directly or

indirectly from claim 1, and claims 23–28, 31–34, and 41 depend directly or indirectly from claim 22. Claims 1, 2, and 3 are reproduced below.

1. A system for tracking the motion of an object relative to a moving reference frame, comprising:
 - a first inertial sensor mounted on the tracked object;
 - a second inertial sensor mounted on the moving reference frame; and
 - an element adapted to receive signals from said first and second inertial sensors and configured to determine an orientation of the object relative to the moving reference frame based on the signals received from the first and second inertial sensors.
2. The system of claim 1 in which the first and second inertial sensors each comprises three angular inertial sensors selected from the set of angular accelerometers, angular rate sensors, and angular position gyroscopes.
3. The system of claim 2, in which the angular inertial sensors comprise angular rate sensors, and the orientation of the object relative to the moving reference frame is determined by integrating a relative angular rate signal determined from the angular rate signals measured by the first and second inertial sensors.

Ex. 1001, 11:50–12:2.

D. Pending Grounds of Unpatentability

The first pending ground of unpatentability challenges independent claims 1 and 22 as containing obvious subject matter, under 35 U.S.C. § 103(a), over the combined teachings of McFarlane¹ and Velger.² The second pending ground of unpatentability challenges claims 2–7, 10–13, 20,

¹ U.S. Patent No. 4,722,601, issued Feb. 2, 1988 (Ex. 1003) (“McFarlane”).

² Mordekhai Velger, HELMET-MOUNTED DISPLAYS AND SIGHTS 1–291 (1998) (Ex. 1004) (“Velger”).

23–28, 31–34, and 41 as containing obvious subject matter, under 35 U.S.C. § 103(a), over the combined teachings of McFarlane, Velger, and Streit.³ Petitioner also relies on the declaration and reply declaration of Dr. Mohinder Grewal in support of its contentions (Ex. 1006; Ex. 1032).

D. Level of Ordinary Skill in the Art

Petitioner’s declarant, Dr. Grewal, testifies that a person of ordinary skill in the art of the ’159 Patent at the time of the alleged invention would have had “at least a Master’s degree in Electrical Engineering or Computer Science, or related field, as well as at least two years of work experience relating to motion tracking.” Ex. 1006 ¶ 31. Patent Owner agrees with this proposed definition of the level of ordinary skill in the art. Tr. 34:9–11. We have considered the parties’ positions and agree with the undisputed definition proffered by Petitioner’s declarant that a person of ordinary skill in the art of the ’159 Patent at the time of the alleged invention would have had at least a Master’s degree in Electrical Engineering or Computer Science, or a related field, as well as at least two years of work experience relating to motion tracking.

II. ANALYSIS

A. Claim Interpretation

In an *inter partes* review, claim terms in an unexpired patent are given their broadest reasonable construction in light of the Specification of the patent in which they appear. 37 C.F.R. § 42.100(b); *Cuozzo Speed Techs., LLC v. Lee*, 136 S.Ct. 2131, 2144–46 (2016). Under the broadest reasonable construction standard, claim terms are presumed to have their ordinary and

³ European Patent App. No. EP 0 762 363 A1, published March 12, 1997 (Ex. 1005) (“Streit”).

customary meaning, as would be understood by one of ordinary skill in the art in the context of the entire disclosure. *In re Translogic Tech., Inc.*, 504 F.3d 1249, 1257 (Fed. Cir. 2007).

In the Decision to Institute, we construed the claim term “moving reference frame” (recited in at least independent claims 1 and 22), as “movable platform.” Inst. Dec. 5. We based this construction on the Specification, which describes the invention as “making possible the use of ‘inertial head-tracking systems on-board *moving platforms*’ using an ‘Inertial Measurement Unit (IMU) . . . rigidly attached to the *moving platform.*”” *Id.* (quoting Ex. 1001, 1:45–49 (emphasis added)). At that time, we declined to incorporate the term “or other body,” into the construction—as proposed by Petitioner—as not supported by the Specification or necessary to the resolution of the issues at that stage of the proceeding. *Id.*

In their respective Response and Reply, neither party disputes the construction we used for purposes of the Decision to Institute. In the absence of dispute, we see no reason to change our construction, which we based on the broadest reasonable interpretation, consistent with the Specification.

*B. Obviousness of Claims 1 and 22
over McFarlane and Velger*

In the Decision to Institute, we determined Petitioner had demonstrated a reasonable likelihood of proving that claims 1 and 22 are unpatentable on the proposed ground of obviousness over McFarlane and Velger. Inst. Dec. 12. Patent Owner does not raise any arguments against this determination except to note that the burden for proving unpatentability remains with Petitioner. Tr. 37:16–19. We agree that we must consider

whether Petitioner has met the burden of proving the unpatentability of claims 1 and 22 on the proposed grounds by a preponderance of the evidence. *See In re Magnum Oil Tools Int'l, Ltd.*, 2016 WL 3974202, at *7 (Fed. Cir. July 25, 2016). We determine the record supports Petitioner's contentions and adopt Petitioner's contentions discussed below as our own. For the reasons given below, after consideration of the parties' contentions and evidence, we conclude that Petitioner has shown by a preponderance of the evidence that claims 1 and 22 of the '159 patent are unpatentable, under 35 U.S.C. § 103, as the subject matter of those claims would have been obvious over the combination of McFarlane and Velger. Before addressing Petitioner's contentions, we begin with a brief summary of McFarlane and Velger.

1. McFarlane (Ex. 1003)

McFarlane describes an apparatus comprising a helmet-mounted display and detector unit to determine the movement of the helmet relative to a predetermined frame of reference. Ex. 1003, Abstract, 1:58–60.

Figure 1 of McFarlane is reproduced below:

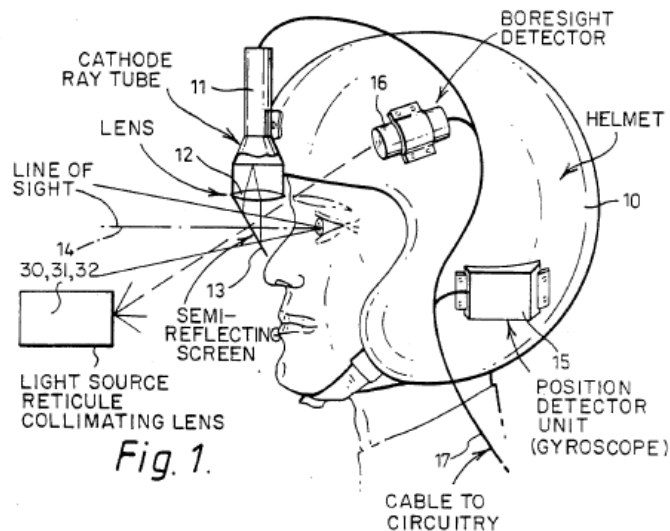

Figure 1 above illustrates the HMD in accordance with the invention of McFarlane. *Id.* at 2:8–16. Helmet 10 includes detector unit 15, which may be “an arrangement of gyroscopes arranged to detect movements of the helmet about the a[z]imuth and elevation axes.” *Id.* at 2:38–42. A signal processor circuit 21 determines the azimuth and elevation from the output signals of the gyroscopes and applies these measurements to display processor 22. *Id.* at 2:42–50, Fig. 2. If the helmet-mounted display is to be used with a movable reference frame, such as a ship or aircraft, allowance is made for such movement, by applying inputs from the ship or aircraft’s inertial platform (i.e., frame azimuth and frame elevation) to display processor 22. *Id.* at 4:8–21, Fig. 2.

2. Velger (Ex. 1004)

Velger is a textbook that teaches “[h]ead-orientation measurement” or “head-tracking” using helmet-mounted inertial sensors, such as three gyroscopes and three accelerometers. Ex. 1004, 166–168. Figure 6.14 of Velger is reproduced below:

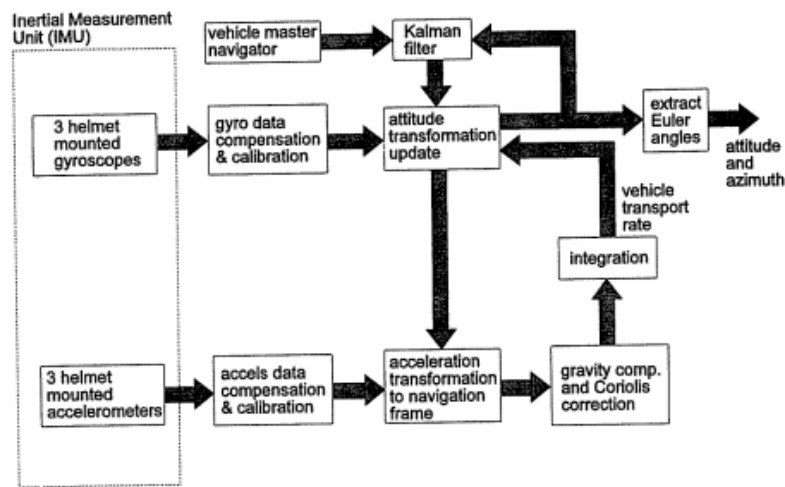

Figure 6.14 Functional block diagram of helmet-pose measurement using strapdown AHRU concept.

Figure 6.14 above illustrates a system receiving inputs from a helmet-mounted inertial measurement unit (IMU) to extract “Euler angles” and compute helmet attitude and azimuth angles. *Id.* at 168. Although the Euler angles measure head orientation relative to the navigation frame of reference, “[t]hey easily can be converted to the vehicle coordinate frame by using the vehicle-orientation measurements obtained by the vehicle master navigator.” *Id.* at 171.

3. Analysis

Petitioner provides a mapping of both McFarlane and Velger to each of the limitations of independent claims 1 and 22. Pet. 24–33. Petitioner contends that the combination of McFarlane and Velger describe: helmet-mounted displays or sights (i.e., the recited “tracked object”) containing gyroscopic sensors (i.e., the recited “first inertial sensor”) (*id.* at 24–26) for use on land or on a moving reference frame such as a ship or aircraft (i.e., the “recited moving reference frame,” which is a “movable platform”) (*id.* at 21, 26–27). Petitioner further directs us to evidence that McFarlane and Velger describe the moving ship or aircraft reference frame as having its own larger and more accurate gyroscopic sensors (i.e., the recited “second inertial sensor”) (*id.* at 21, 26–27) and containing processors to receive input from both the helmet-mounted sensors and the ship- or aircraft-based sensors and determine at least attitude and azimuth angles relative to the ship or aircraft (i.e., “an element adapted to receive signals . . . and configured to determine an orientation of the object relative to the moving reference frame . . .”) (*id.* at 27–28). We determine the record supports Petitioner’s mappings and adopt them as our own.

Petitioner also presents a rationale as to why a person of ordinary skill in the art at the time of the invention would combine the teachings of McFarlane and Velger. Pet. 22–24; Ex. 1006 ¶¶ 57–58. According to Petitioner, although McFarlane teaches calculating azimuth and elevation angles, it assumes an environment where “‘roll’ movements, are less likely.” Ex. 1003, 2:21–22. However, Velger is directed at high-G applications, such as in combat aircraft, and, as such, “a POSITA would recognize the need for to account for the third degree of freedom, the side-to-side (roll) component of the HMD’s movement.” Pet. 23; *see also* Ex. 1006 ¶ 57. Based on these contentions, Petitioner presents reasoning that a person of ordinary skill in the art would have incorporated the teachings of Velger, which accounts for azimuth, elevation, *and* roll angles and provides a detailed “architecture and mathematics,” into the system of McFarlane to obtain the predictable result of tracking the object (e.g., the helmet-mounted display) in all three axes of rotation. Pet. 24; *see also* Ex. 1006 ¶¶ 57–58.

Patent Owner presents no specific rebuttal to Petitioner’s proposed rationale for combining McFarlane and Velger in its challenge to claims 1 and 22, other than to contend the proposed combination is the result of impermissible hindsight. PO Resp. 27–28. We disagree. Both McFarlane and Velger present teachings for determining orientation on movable platforms, although McFarlane assumes a more limited environment where roll is “less likely.” Ex. 1003, 2:21–22. Therefore, we agree with Petitioner and its declarant that a person of ordinary skill in the art, seeking to modify McFarlane to account for a third degree of freedom, would have been motivated to consult Velger, which is specifically directed a high-G environments, such as combat aircraft, to obtain the tracking with three axes

of rotation. *See* Ex. 1006 ¶ 57. Consequently, we determine the record supports Petitioner’s articulated reasoning in support of its conclusion of obviousness and we adopt its contentions as our own. *See KSR Int’l Co. v. Teleflex, Inc.*, 550 U.S. 398, 399 (citing *In re Kahn*, 441 F.3d 977, 988 (Fed. Cir. 2006)).

Accordingly, for the foregoing reasons, we determine Petitioner has satisfied its burden of proving obviousness against claims 1 and 22 by a preponderance of the evidence.

C. Alleged Obviousness of Claims 2–7, 10–13, 20, 23–28, 31–34, and 41 over McFarlane, Velger, and Streit

Petitioner contends claims 2–7, 10–13, 20, 23–28, 31–34, and 41 are unpatentable as obvious over the combination of McFarlane, Velger and Streit. Pet. 33–59; *see also* Ex. 1006 ¶¶ 60–71. Patent Owner responds that at least claims 3–5, 7, 10, 12, 13, 24–26, 31, and 33–34 “contain features not disclosed or fairly suggested in McFarlane, Velger, Streit, or a combination thereof.” PO Resp. 22. Although Patent Owner presents no specific rebuttals as to claims 2, 6, 11, 20, 23, 32, and 41, we consider, as before, whether Petitioner has met the burden of proving the unpatentability of these claims on proposed grounds by a preponderance of the evidence, before turning to Petitioner’s arguments for the remaining claims.

1. Claims 2, 6, 11, 20, 23, 32, and 41

Dependent claims 2, 11, 23, and 32 recite various specific requirements for the first and second inertial sensors, such as requiring these sensors to comprise three linear-accelerometers. *See, e.g.*, Ex. 1001, 12:38–40 (claim 11). As part of its proposed combination of McFarlane, Velger, and Streit, Petitioner contends the specific requirements of the first inertial

sensor are disclosed by the helmet-mounted IMU of Velger, while the requirements of the second sensor as disclosed by the vehicle-mounted IMU of Streit. Pet. 37 (citing, e.g., Ex. 1004, 168; Ex. 1005, 3:34–37); *see also id.* at 42–43, 54.

Dependent claims 6 and 27 recite mathematical operations used to determine the orientation of the tracked object, such as requiring computing the orientation of the object with respect to a fixed inertial reference frame, computing the orientation of the moving reference frame with respect to the same fixed inertial reference frame, and then computing the relative orientation based on those two orientations. *See, e.g.*, Ex. 1001, 12:12–21 (claim 6). Petitioner argues that based on the teachings of McFarlane, Velger, and Streit, a person of ordinary skill in the art would understand the orientation of the head-mounted display and the orientation of the vehicle (i.e., moving reference frame) could each be determined relative to a fixed inertial reference frame before mathematically relating these two orientations to each other. Pet. 37–39 (citing, e.g., Ex. 1004, 171). For example, Petitioner directs us (Pet. 38–39) to Velger’s description of calculating the Euler angles (azimuth, elevation, and roll) of the head orientation relative to the “navigation frame” (i.e., an inertial reference frame), which “easily can be converted to the vehicle coordinate frame [(i.e., the moving reference frame)] by using the vehicle-orientation measurements obtained by the vehicle master navigator.” Ex. 1004, 171; *see also* Ex. 1006 ¶ 52.

Dependent claims 20 and 41 recite that the moving reference frame is associated with a vehicle, while the second inertial sensor was installed on the vehicle for the purpose of navigation. *See, e.g.*, Ex. 1001, 13:16–19

(claim 20). Petitioner directs us to McFarlane and Velger’s description of a moving reference frame that is a ship or aircraft (i.e., a vehicle), which have pre-existing navigation units referred to as an “inertial platform” or “vehicle master navigator,” respectively. Pet. 41–42 (citing, e.g., Ex. 1003, 2:62–64; Ex. 1004, 171); *see also* Ex. 1006 ¶ 59.

We determine the record supports Petitioner’s mappings of McFarlane, Velger, and Streit to the limitations of claims 2, 6, 11, 20, 23, 27, 32, and 41 and adopt them as our own. In addition, Petitioner contends a person of ordinary skill in the art would have reason to implement the specific navigation systems described in Streit in the IMUs described more generally in McFarlane and Velger to obtain the predictable result of a system to track the orientation of an object about three axes of rotation. *Id.* at 34–36 (citing Ex. 1006 ¶ 71). We determine the record supports Petitioner’s articulated reasoning in support of its conclusion of obviousness. *See KSR*, 550 U.S. at 418 (citing *Kahn*, 441 F.3d 977). Accordingly, for the foregoing reasons, we determine Petitioner has satisfied its burden of proving obviousness against claims 2, 6, 11, 20, 23, 27, 32, and 41 by a preponderance of the evidence.

2. Claims 3–5, 24–28, and 31

Dependent claims 3 and 24 recite a mathematical order for determining the orientation of the object. Specifically, both claims recite that the “orientation of the object relative to the moving reference frame is determined by integrating a relative angular rate signal determined from the angular rate signals measured by the first and second inertial sensors.” Ex. 1001, 11:65–12:2, 13:32–37. In its Petition, Petitioner contends McFarlane and Velger compute the orientation of the HMD (i.e., the object)

relative to free or inertial space by twice integrating the output of their gyroscopes, and that Streit computes the orientation of the *vehicle* (i.e., the moving reference frame) relative to inertial space by twice integrating the output of its gyroscopes. Pet. 37–38 (citing Ex. 1004, 168–170; Ex. 1003, 4:8–12; Ex. 1005, 1:55–2:1). Petitioner further contends McFarlane and Velger disclose obtaining the orientation of the HMD relative to the vehicle by offsetting the HMD’s orientation with the vehicle’s orientation. *Id.* at 38 (citing Ex. 1003, 4:15–21). Although claim 3 requires first relating the motion of the helmet to the vehicle and then integrating to obtain relative orientation (Ex. 1001, 11:65–12:2), Petitioner contends a person of ordinary skill would have understood this to be mathematically equivalent to integrating the two angular motions first to obtain then obtaining the relative orientation, according to the following property of integrals:

$$\int f(x) \pm g(x) dx = \int f(x) dx \pm \int g(x) dx$$

Pet. 38–39 (citing Ex. 1006 ¶ 68).

In its Response, Patent Owner contends the cited references teach the “old way” of computing relative orientation, by first integrating the signal output of each angular rate sensor (i.e. object and reference frame) to compute orientation of each relative to ground, and then computing the orientation of the object relative to the moving reference frame as discussed above. PO Resp. 33. By contrast, Patent Owner contends, claims 3 and 24 teach the “new way” of computing relative orientation by integrating a “relative angular rate signal,” (i.e., object relative to moving reference frame) determined from “raw signal data.” *Id.* at 33–34 (citing Ex. 2001 ¶¶ 41–47). Patent Owner contends none of the cited references teach such a “relative angular rate signal.” *Id.* at 33 (citing Ex. 2001 ¶ 97–99). Patent

Owner argues Petitioner’s attempt to equate the “old way” and the “new way”⁴ using the 1-dimensional sum of integrals principle oversimplifies the claims and ignores the nuances of determining relative orientation in a real-world application having 2 or 3 degrees-of-freedom. *Id.* at 34–35.

Moreover, because the cited references rely on the old way and provide no hint or perceived need to determine a “relative angular rate signal” prior to determining orientation, we determine Petitioner fails to sufficiently establish that a person of ordinary skill in the art would have applied the sum of integrals principle as proposed. *See id.* at 35 (citing Ex. 2001 ¶ 116). We are persuaded by Patent Owner’s arguments.

As an initial matter, we agree that no cited reference teaches or suggests the recited “relative angular rate signal,” which can be then integrated to obtain relative orientation. In responding to Patent Owner, Petitioner and Dr. Grewal contended “McFarlane discloses using a relative angular rate signal to determine relative orientation” (Ex. 1032 ¶ 26; *see* Reply 15–17), but at the oral hearing Petitioner conceded this is not disclosed by any prior art of record. *See* Tr. 15:8–17 (“[The relative angular rate signal] is *not explicitly disclosed*. We would agree with that.” (emphasis added)). Instead, as of the hearing, Petitioner contends McFarlane is silent on whether it uses the old way or new way and, therefore, a person of ordinary skill in the art could have understood McFarlane to teach combining the head orientation and reference frame

⁴ As Petitioner also adopted the term “new way” to refer to the order of operations set forth in claim 3, and “old way” to refer to separately integrating the object and moving reference frame orientation, we also adopt this terminology for convenience.

orientation prior to integrating in display processor 22 to obtain a relative angular rate signal then integrating:

And so what we are saying is you know you are going to take those two signals, you are going to subtract them and relate them. We're saying it doesn't matter which order you do it in. And McFarlane is not explicit as to which way he does it. The record reflects that it is obvious to do it either way.

Tr. 14:18–23; *see also* Tr. 10:17–11:6 (“[FAZ and FEL] could be either the incremental angle or it could be the change in the angle over time.”).

We disagree, because McFarlane is clear that it uses the old way, not the new way. Specifically, as Patent Owner points out (Tr. 21:1–7), McFarlane specifically states that the azimuth and elevation *angles* (i.e., AZ, EL, FAZ, and FEL) are applied to display signal processor 22 in Figure 2 (Ex. 1003, 2:49–52 (“These azimuth and elevation angles are applied to a display signal processor 22.”)). Thus, to have determined the object angles AZ and EL, and, separately, the reference frame angles FAZ and FEL, from the angular rates, the integration step in McFarlane must have occurred separately for the object and the moving reference frame *before display signal processor 22*. *See* Ex 1003, 2:49–52; Tr. 11:11–16, 20:12–16. By integrating each angular rate separately to obtain each orientation, McFarlane unambiguously uses the old way, not the new way required by claim 3. This reading of McFarlane is consistent with the testimony of Patent Owner’s declarant, Dr. Welch, which we credit in this regard. *See* Ex. 2001 ¶¶ 104–105. Other than directing us to McFarlane, Dr. Grewal does not discuss the recited relative angular rate signal. Consequently, as we stated above, Petitioner has not directed us to prior art of record that

allegedly teaches the “relative angular rate signal” from which to implement the new way.

We have considered Dr. Grewal’s opinion, based on an introductory calculus textbook (Ex. 1026), that a person of ordinary skill would have understood the new way required in claim 3 to be “equivalent” to the old way. Ex. 1032 ¶ 15. However, Dr. Grewal admitted that the application of the sum of integrals principle in the context of navigation equations was not supported by evidence of record:

Q My question is simpler than that. I’m simply asking you whether you -- you show that work in your reply declaration. In your reply declaration, you did not show how the sum difference property of integrals applies to the navigation equations, correct?

A That is correct. But from my understanding, it can be extended very easily.

Q In your declarations, you don’t reference any other publications that derive the mathematics of the new way from the mathematics of the old way, correct?

THE DEPONENT: That’s correct.

Ex. 2020, 17:8–24 (objection omitted).⁵ Because Dr. Grewal’s “understanding” that the new way and old way are equivalent in the context of the invention is unsupported, we give it little weight. *See* 37 C.F.R. § 42.65(a) (“Expert testimony that does not disclose the underlying facts or data on which the opinion is based is entitled to little or no weight. Testimony on United States patent law or patent examination practice will not be admitted”). Moreover, Dr. Grewal’s understanding still does not

⁵ Regarding this testimony, we have considered Petitioner’s Response to Patent Owner’s Motion for Observation, but this response merely restates the evidence Dr. Grewal does offer, namely his opinion based on a calculus textbook. *See* Paper 42, 3.

account for the recited relative angular rate signal limitation, which Dr. Grewal does address anywhere in his opinion. In view of these deficiencies, we are persuaded by Patent Owner and determine Petitioner fails to establish beyond a preponderance of the evidence that it would have been obvious to one of ordinary skill in the art to apply the sum of integrals principle to obtain claim 3. *See* PO Resp. 35.

Consequently, for the foregoing reasons, we are not persuaded Petitioner has met its burden of proving claims 3 and 24 unpatentable by a preponderance of the evidence. Because dependent claims 4, 5, 25–28, and 31 depend directly or indirectly from either of claim 3 or claim 24, Petitioner has not satisfied its burden with respect to these claims as well.

3. Claims 4, 5, 7, 10, 25, 26, 28, and 31

Patent Owner also challenges Petitioner’s arguments as to claims 4, 5, 7, 10, 25, 26, 28, and 31, each of which recites limitations relating to “drift correction.” PO Resp. 37. In its Petition, Petitioner relies on disclosures in McFarlane, Velger, and Streit as each teaching these limitations. Pet. 39–40. For example, we agreed for purposes of institution (Inst. Dec. 11), that McFarlane’s disclosure of boresight detector 16 on the HMD, which corrects inertial drift errors, is a non-inertial subsystem for connecting drift as variously recited in the foregoing claims. Ex. 1003, 2:12–16, 3:16–25; *see also* Ex. 1032 ¶ 28.

In its Response, Patent Owner argues that the claims reciting drift correction limitations depend direct or indirectly from claims 2 or 23, which require three angular rate sensors and, therefore, “these claims are directed to the correction of drift in three-dimensional (3DOF) orientation.” PO Resp. 37 (citing Ex. 2001 ¶¶ 122–124). Patent Owner also argues that the

optical boresight detector disclosed in McFarlane merely detects “a predetermined orientation” and then resets the orientation determined by the inertial sensors. *Id.* at 38–39 (citing Ex. 1003, 3:10–11). As such, Patent Owner contends, it does not measure anything and, therefore, does not “provide an independent measurement,” as recited in claim 4 (and a similar limitation in claim 10). *Id.* (citing Ex. 2001 ¶ 132).

In its Reply, Petitioner responds that nothing in the claims “ties drift correction to the inertial sensors or requires the drift corrector to detect orientation in three dimensions.” Pet. Reply 18; *see also* Ex. 1032 ¶ 28. And, as to Patent Owner’s contention that McFarlane’s boresight detector does not independently measure, Petitioner quotes the following statement in McFarlane:

an *array of light sources* and a suitable detector such that a degree of misalignment may be tolerated. This misalignment is *measured* and is used by the alignment correction circuitry. Such an arrangement makes misalignment about the roll axis easier to measure and correct.

Pet. 22 (quoting Ex. 1003, 3:47–53). Petitioner contends this statement not only rebuts Patent Owner’s contention that McFarlane’s boresight detector does not measure and correct errors, but also, by correcting misalignment about the “roll axis,” indicates the system corrects drift in all three degrees of freedom (i.e., yaw, pitch, and roll). *Id.* (citing Ex. 1032 ¶ 29).

As an initial matter, we are not persuaded by Patent Owner’s proposed construction. First, Patent Owner does not direct us to support for its contention that the three sensors recited in claims 2 or 23 must be used to “determine orientation” in three degrees of freedom. More significantly, even if such a limitation should be read into claim 2 or 23, Patent Owner

fails to provide any support—other than statements of Dr. Welch—that the recited non-inertial drift corrector, as in claim 4, must correct for drift in all three degrees of freedom to be considered a “drift corrector.” *See* PO Resp. 39 (citing Ex. 2001 ¶¶ 163–164). We do not give substantial weight to this testimony because it simply asserts, without explanation, that correcting for drift in two dimensions in a three-dimensional system would not be considered drift correction. *See* Ex. 2001 ¶¶ 163–164; *see also* 37 C.F.R. § 42.65(a). Conversely, Petitioner cites evidence that a two-dimensional drift corrector would have been considered a drift corrector even in a three dimensional system. Pet. Reply 18 (citing Ex. 1030, 2 (referring to drift correction using a two-axis fluid inclinometer)). Accordingly, we are persuaded that McFarlane teaches the required drift correction.

As to Patent Owner’s argument that McFarlane’s drift corrector does not provide independent *measurements*, we are also unpersuaded. The cited portion of McFarlane (quoted above) occurs in a lengthy description of the boresight detector in column 3. *See* Ex. 1003, 3:26–53. As Petitioner points out, there the boresight detector is described, in one arrangement, as an array of light sources and a suitable detector in which any misalignment is measured and used by the alignment correction circuit to correct misalignment about the roll axis. *Id.* at 3:47–53. We find this disclosure supports Petitioner’s position that McFarlane’s boresight detector, in at least one arrangement, teaches performing measurements and correcting drift accordingly.⁶

⁶ The fact that McFarlane states this correction is applied to the “roll axis” also supports Petitioner’s contention that a person of ordinary skill in the art would have understood that McFarlane’s drift correction system is a capable

Accordingly, we find Petitioner has shown that McFarlane's boresight detector teaches a non-inertial sensor for correcting drift as recited by the disputed claims. As such, it is unnecessary to address Patent Owner's remaining arguments as to whether Velger or Steight teach or suggest these limitations. *See* PO Resp. 39–42. For the foregoing reasons, we determine Petitioner has met its burden of proving claims 7 and 10 unpatentable by a preponderance of the evidence.⁷

4. Claims 12, 13, 33, and 34

Patent Owner challenges Petitioner's arguments with respect to claims 12 and 33, which recite limitations directed to calculating a position—as opposed to an orientation—relative to the moving reference frame. PO Resp. 42. According to Patent Owner, as these claims depend from claims 11 and 32, they also require three linear accelerometers, and, therefore require determining position in three degrees of freedom. *Id.* (citing Ex. 1001, 12:38–40, 14:9–11). Patent Owner contends McFarlane does not disclose accelerometers to determine position, Streit does not have an object moving relative to a reference frame, and Velger only uses linear accelerometers to measure helmet and vehicle acceleration (i.e., combined object and moving reference frame position). *Id.* at 43–45 (citing Ex. 2001 ¶¶ 199, 202–204, 209–210, 213–214). Consequently, Patent Owner argues, none of the references alone or in combination teach determining the

of correcting drift in three dimensions, although this is not required in view of our determination above that the claims do not require drift correction in three dimensions.

⁷ As discussed above, we determine Petitioner has not met its burden of proving unpatentability with respect to claims 4–5, 25, 26, 28, and 31. However, this determination does not address claims 7 and 10.

position of the object relative to the moving reference frame in three degrees of freedom. *Id.* at 45.

Petitioner contends neither claim 12 nor claims 33 require using the linear accelerometers recited in claims 11 and 32 to perform the claimed calculating function, and Patent Owner has not provided any analysis that would support incorporating such a limitation into these claims. Pet. Reply. 24. Thus, according to Petitioner, McFarlane's and Velger's magnetic, optical, and acoustic systems for determining position of an object relative to a moving reference frame disclose the limitations of claims 12 and 33. *Id.* at 24 (citing Pet. 40–41, 54–58).

As with its claim construction arguments above, we do not find Patent Owner's attempt to limit the claims here to be persuasive. As Petitioner points out, the claims do not themselves recite that the three linear accelerometers in the antecedent claims be used to determine object position (in three degrees of freedom or otherwise) and Patent Owner directs us to no support or analysis to the contrary.

Petitioner directs us to magnetic and optical systems in McFarlane and Velger as satisfying claims 12 and 13. *See* Pet. 40–41 (citing, e.g., Ex. 1003, 1:33–39, 2:30–36; Ex. 1004, 147). We are persuaded by this evidence. For example, the cited portion of McFarlane discloses that electromagnetic sensor coils may be carried on the user's helmet (i.e. the object) and a radiator may be carried by the reference frame. Ex. 1003, 1:33–36. McFarlane states that the “radiator and the sensor are arranged such that the orientation and position of the helmet . . . is determined by the voltages induced in the sensor coils.” *Id.* at 1:36–39. We agree with Petitioner and Dr. Grewal that this description teaches claim 12's requirement for an

element for calculating the position of the object relative to the moving reference frame. *See* Ex. 1006 ¶¶ 36, 66. Similarly, we also observe Velger’s description of electromagnetic receivers mounted on the helmet and transmitters mounted in the vehicle for determining the recited “relative position and orientation between the transmitter and the receiver.” Ex. 1004, 147.

Accordingly, we are persuaded that Petitioner has shown McFarlane and Velger each teach the limitations of claims 12 and 33. As such, we determine Petitioner has met its burden of proving claims 12 and 33 unpatentable by a preponderance of the evidence.

5. Claims 13 and 34

Patent Owner also disputes Petitioner’s arguments with respect to claims 13 and 34, which recite limitations for double integrating a relative linear acceleration signal computed from the linear accelerometer signals recited in claims 11 and 32 respectively. PO Resp. 46. Patent Owner contends, at best, the cited references would only inform determining position using the “old way” (i.e., integrating each of the linear accelerometer signals, before determining the relative position). *Id.* Consequently, none of the references teach or suggest a relative linear accelerometer signal. *Id.*

In its Reply, Petitioner argues that “[a]s explained above [in regards to claims 3 and 24], the sum/difference of integrals principle holds that relating two signals before integrating them is mathematically and practically equivalent to integrating them before relating them.” Pet. Reply 25. For reasons similar to those explained above, we do not find Petitioner’s reasoning persuasive. As with the “relative angular rate signal” of claim 3,

Petitioner's evidence or analysis that a person of ordinary skill in the art would have known to use the recited "relative linear accelerometer signal" is to retroactively apply the sum of integrals property outside the context of navigation equations and without showing evidence of the existence of the recited "relative linear acceleration signal," which could be integrated instead. *Id.*; *see also* Ex. 1006 ¶ 70.

Accordingly, we are not persuaded Petitioner has met its burden of proving claims 13 and 34 unpatentable by a preponderance of the evidence.

III. CONCLUSION

Petitioner has shown by a preponderance of the evidence that claims 1, 2, 6, 7, 10, 11, 12, 20, 22, 23, 32, 33, and 41 of the '159 patent are unpatentable. Petitioner, however, has not shown by a preponderance of the evidence that 3, 4, 5, 13, 24, 25, 26, 27, 28, 31, and 34 of the '159 patent are unpatentable.

IV. ORDER

In consideration of the foregoing, it is hereby:

ORDERED that claims 1, 2, 6, 7, 10, 11, 12, 20, 22, 23, 32, 33, and 41 of the '159 patent have been shown to be unpatentable;

FURTHER ORDERED that claims 3, 4, 5, 13, 24, 25, 26, 27, 28, 31, and 34 of the '159 patent have not been shown to be unpatentable; and

FURTHER ORDERED that, because this is a Final Written Decision, parties to the proceeding seeking judicial review of the decision must comply with the notice and service requirements of 37 C.F.R. § 90.2.

IPR2015-01095
Patent 6,474,159 B1

PETITIONER:

Andrea G. Reister
Jay I. Alexander
COVINGTON & BURLING LLP
areister@cov.com
jalexander@cov.com

PATENT OWNER:

Meredith Martin Addy
Daniel Konieczny
Tabet DiVito & Rothstein LLC
maddy@tdrlawfirm.com
dkonieczny@tdrlawfirm.com